

COMBI SYSTEM TYPE M 800 L & 1400 L

with stoker-inlet on the side of the boiler

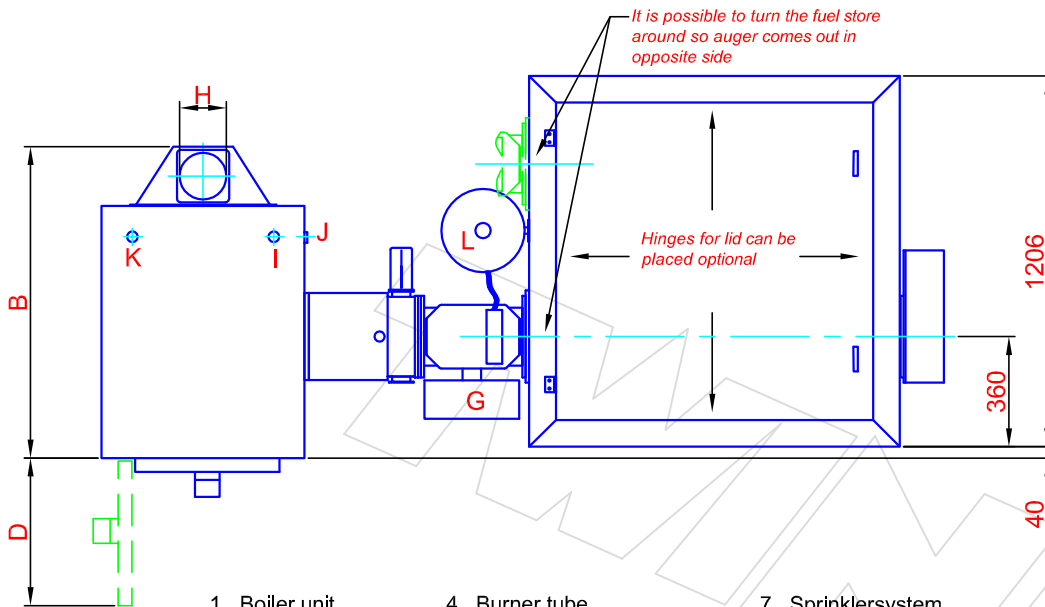
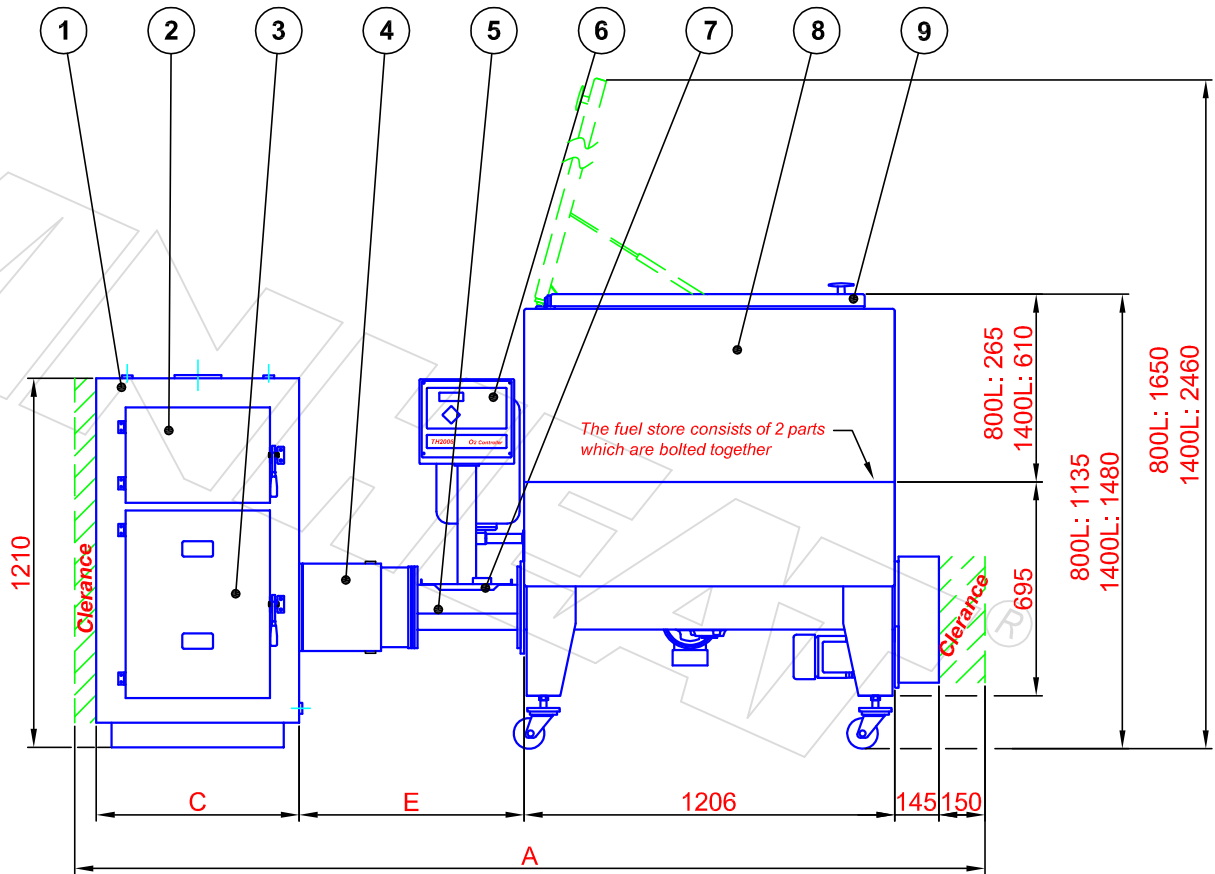

- 1. Boiler unit
- 2. Cleaning door
- 3. Boiler door
- 4. Burner tube
- 5. Auger channel
- 6. Controller
- 7. Sprinklersystem
- 8. Fuel store 800 or 1400 litre
- 9. Lid

Type	Dimensions					Connections					
	A	B	C	D	E	G	H	I	J	K	L
M20i	2950	1015	660	500	720	Electrical con.	Ø153	G1"	G1"	G1"	G 1/2"
M40i	3200	1450	660	500	970	Optional single phase 230V or 3 phase 400V	Ø185	G1 1/2"	G1 1/2"	G1 1/2"	
M80i	3850	1480	960	800	1270		Ø213	G2"	G2"	G2"	

Dimensions in mm.

Twin Heat A/S • Nørrevangen 7 • DK9631 Gedsted
 Mail: twinheat@twinheat.dk • www.twinheat.dk

We reserve the rights to make changes March 2011

With stoker-inlet on the rear of the boiler

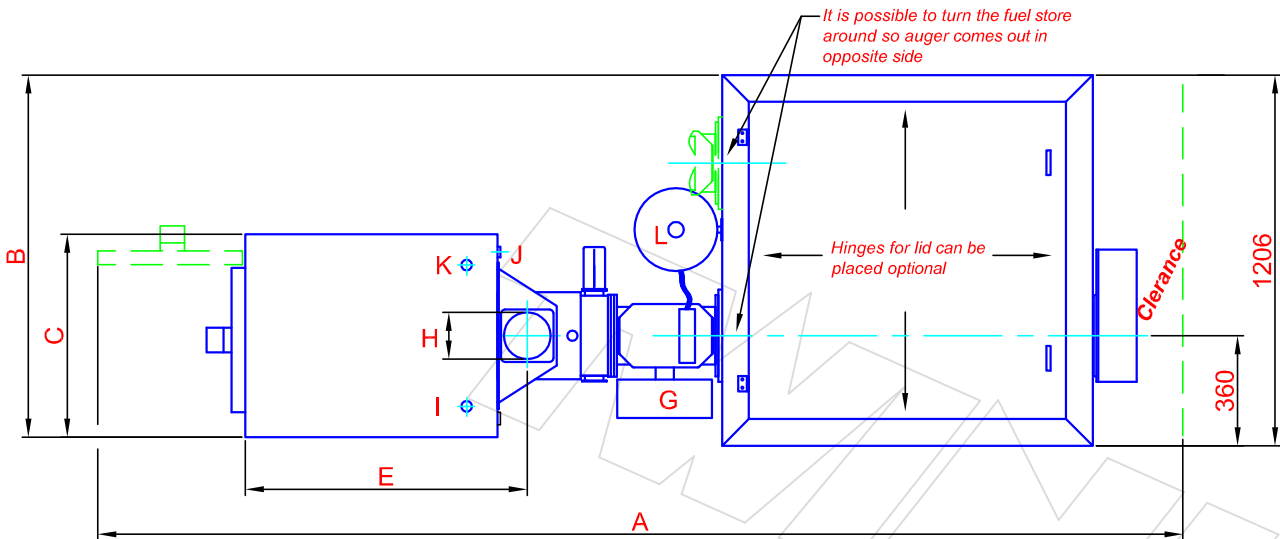
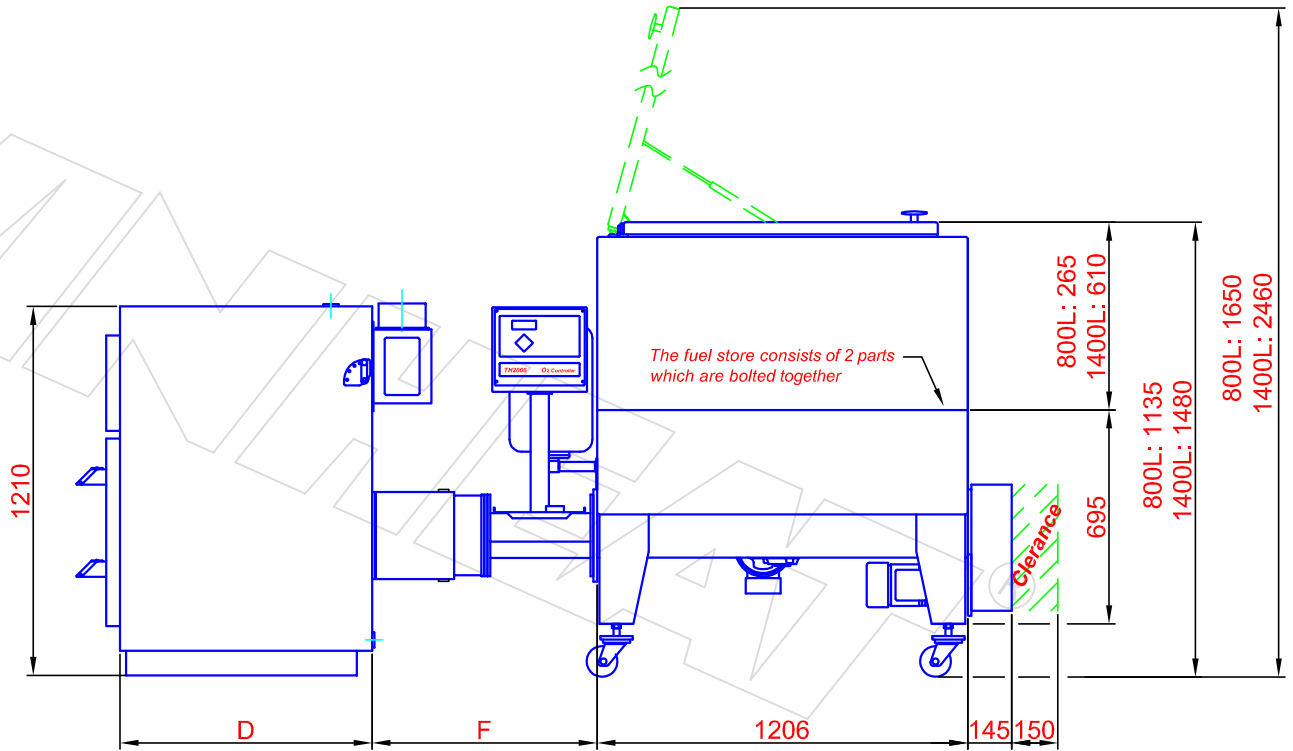

Type	Dimensions						Connections					
	A	B	C	D	E	F	G Electrical cont.	H Flue spigot	I Flow	J Return	K Expansion	L Sprinkler
M20i	3540	1178	660	820	920	720		Ø153	G1"	G1"	G1"	
M40i	4190	1178	660	1220	1330	970	Optional single phase 230V or 3 phase 400V	Ø185	G1½"	G1½"	G1½"	G ½"
M80i	4790	1328	960	1220	1350	1270		Ø213	G2"	G2"	G2"	

Dimensions in mm.