



Authorized Dealer:
Global Sales Group, LLC
P.O. Box 1835 * Chico, CA 95927
Toll Free: 877-474-5521
Office: 530-893-2444
www.globalsalesgroupllc.com



DC-100ID 10 HP In/Out Door Dust Collect System
DC-150ID 15 HP In/Out Door Dust Collect System
DC-200ID 20 HP In/Out Door Dust Collect System
DC-250ID 25 HP In/Out Door Dust Collect System

Features:

- Enclosure cover for rain or snow protection.
- Simple, easy set up and operation.
- Manually operate shaker / vibrate device to easily clean the upper filter bags.
- Motor can be installed with outlets facing up or down regard to your requirement.
- High capacity, low noise.
- Easily dispose of dust from the collection bag or barrel.
- Heavy-duty steel metal frame and base construction.
- Extra large radial-fin type steel impeller for high efficiency air flow.
- Heavy-duty totally enclosed industrial motor for maximum air suction and extended service life.
- Low sound levels to keep the working area quiet.

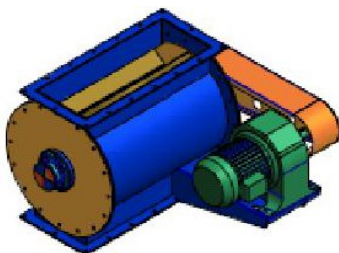

Optional DC-AIL02 2HP AIR LOCK

(Training and installation, tooling & rigging are optional)
(Customer is responsible for local regulations and connecting utilities)

SPECIFICATIONS	DC-10OID	DC-15OID	DC-20OID	DC-25OID
Blower Motor	10 HP 3 PH	15 HP 3 PH	20 HP 3 PH	25 HP 3 PH
Air Capacity (CFM)	5100	8800	9550	10600
Sound Rating (db)	85 ~ 95	85 ~ 95	85 ~ 95	85 ~ 95
Air Speed (ft/s)	109	106	116	125
Filter Bag Size (Dia x L)	24" x 71"	16" x 71"	16" x 71"	24" x 71"
Filter Bag Quantity	3	12	12	6
Collect Bag Size (Dia x L)	24" x 55"	24" x 55"	24" x 55"	24" x 55"
Collect Bag Quantity	3	4	4	6
Inlet Size (Dia)	12"	16"	16"	16"
Machine Length (L)	119"	157"	157"	202"
Machine Width (W)	39"	39"	39"	39"
Machine Height (H)	124"	124"	124"	131"
Machine Weight (LBS)	740	880	930	1050



DC-100ID

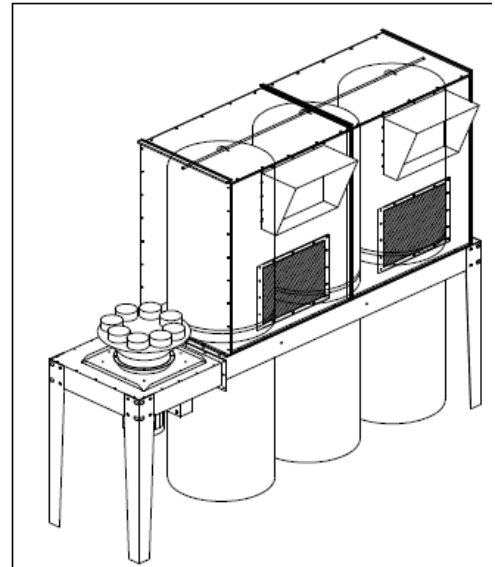
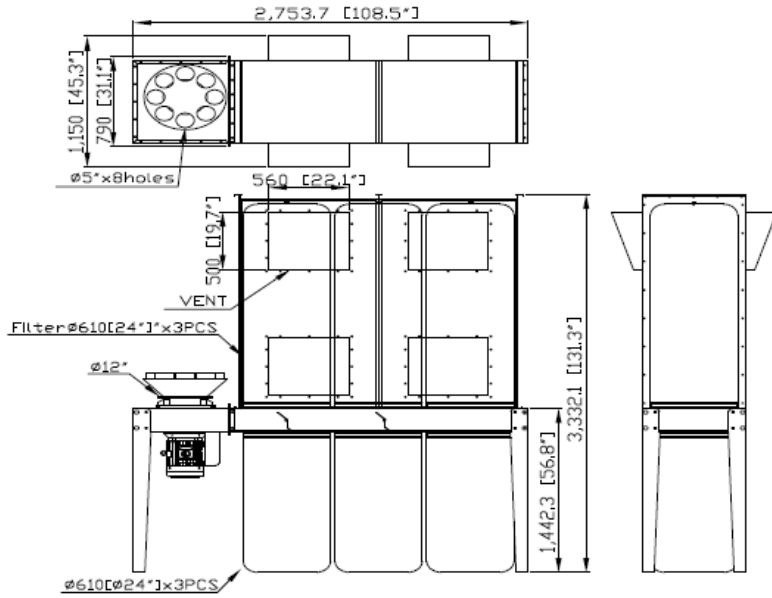

DC-150ID - DC-200ID

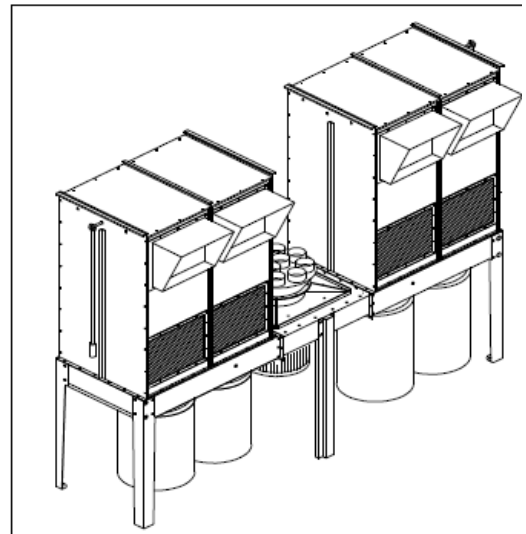
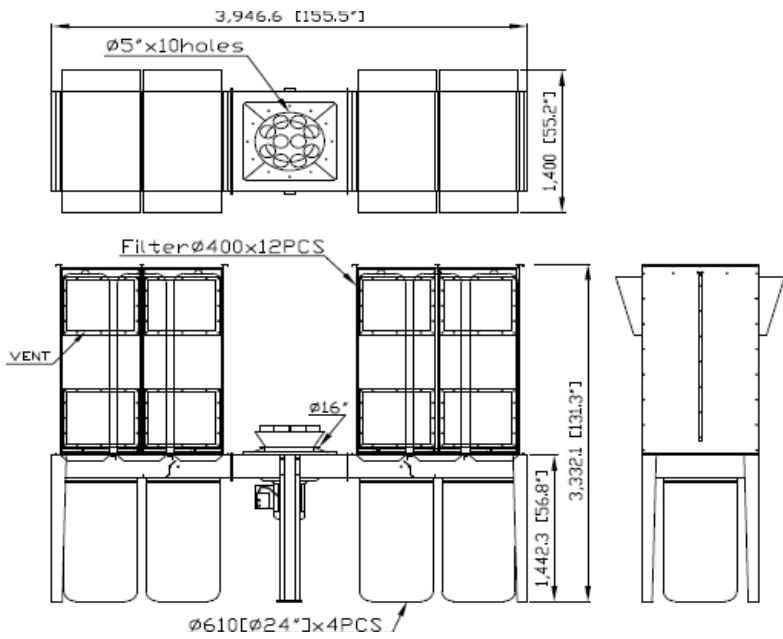

DC-250ID

