



**Authorized Dealer:**  
Global Sales Group, LLC  
P.O. Box 1835 \* Chico, CA 95927  
Toll Free: 877-474-5521  
Office: 530-893-2444  
www.globalsalesgroupllc.com



**30 – 40 HP**



**50 HP**

**DC-300D 30 HP Outdoor Dust Collect System**  
**DC-400D 40 HP Outdoor Dust Collect System**  
**DC-500D 50 HP Outdoor Dust Collect System**

**Features:**

- Functions all in one as Collecting, Filtering, Storage and Outfeeding.
- The needle-felt top bags for optimum filtration efficiency.
- Individual access doors for each filter module, requiring low maintenance.
- Pulse Jet system; Automatically pulses the top bags letting the dust fall into lower collection trucks.

- Optional Air return device to deliver clean air back to working environment.
- Heavy steel metal frame and base.
- Optional Screw conveyor base and Rotary air lock system for automated dust particle delivery.
- Extra large radial-fin type steel impeller for high efficiency air flow.
- Heavy-duty totally enclosed industrial motor for maximum air suction and extended service life.
- Low sound levels to keep the working area quiet.
- Auto air vibration clean device to automatically clean the filter at setting time by itself.
- Equipped with the rotary valve for outfeed material.
- Storage space can be custom designed.

(Training and installation, tooling & rigging are optional)

(Customer is responsible for local regulations and connecting utilities)

SPECIFICATIONS	DC-300D	DC-400D	DC-500D
Blower Motor	30 HP 3 PH	40 HP 3 PH	50 HP 3 PH
Air Capacity (cfm)	11649	13200	16770
Sound Rating (db)	85 ~ 95	85 ~ 95	85 ~ 95
Air Speed (ft/s)	93	93	93
Filter Bag Diameter	5.5"	5.5"	6"
Filter Bag Quantity	64	96	96
Air Inlet Size (Dia)	20"	22"	24"
Machine Length (L)	238"	307"	311"
Machine Width (W)	135"	129"	129"
Machine Height (H)	218"	218"	218"
Machine Weight (LBS)	5500	6620	7760

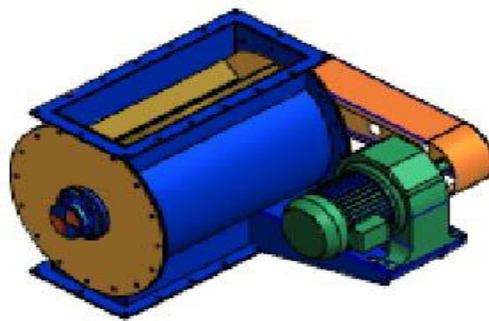

**Optional; DC-AIL02 2HP AIR LOCK**