

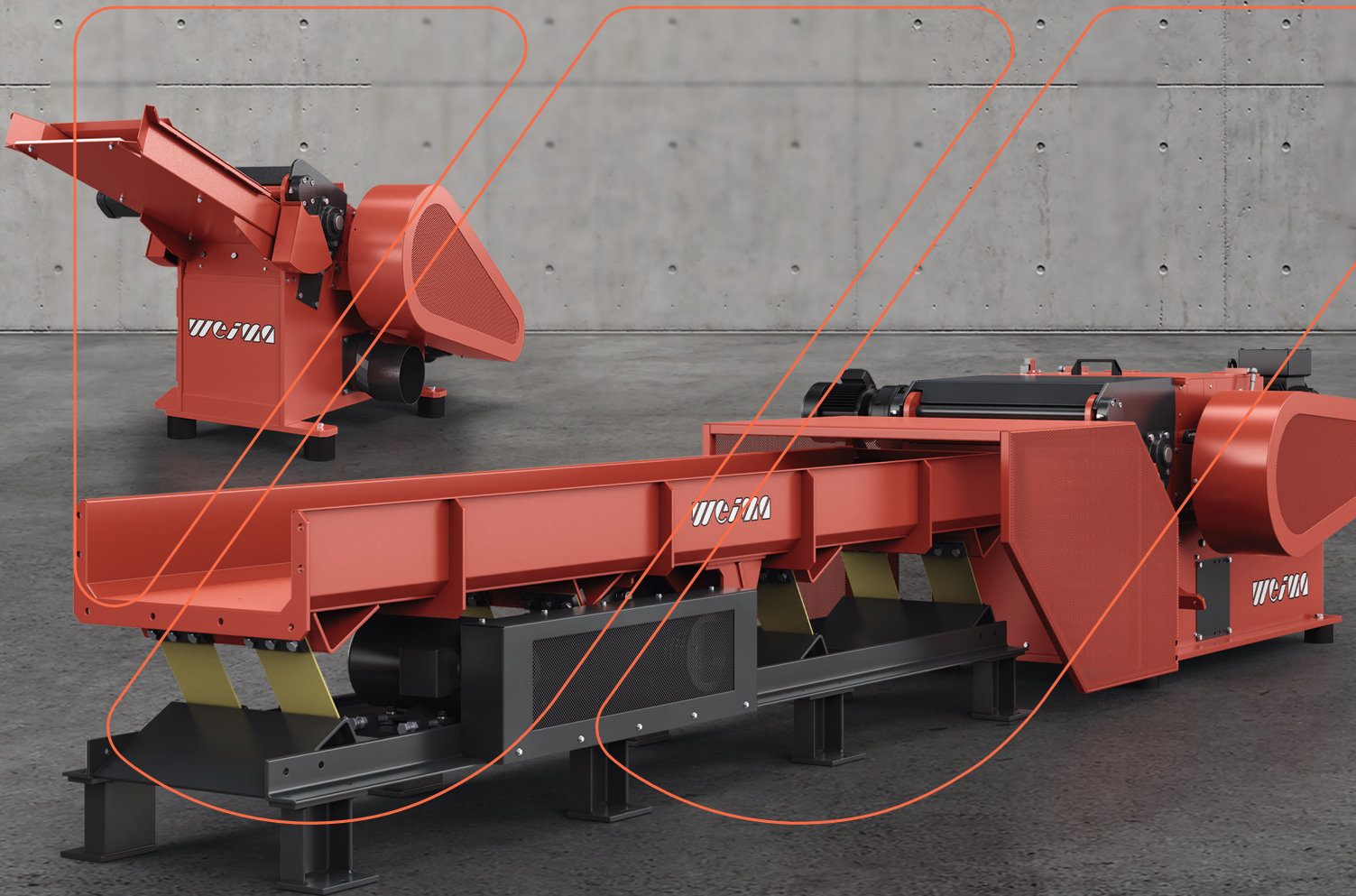

**Authorized Dealer:**  
Global Sales Group, LLC  
P.O. Box 1835 \* Chico, CA 95927  
Toll Free: 877-474-5521  
Office: 530-893-2444  
[www.globalsalesgroupllc.com](http://www.globalsalesgroupllc.com)



SHREDDING + COMPRESSING



 **WLH SERIES  
HORIZONTAL SHREDDERS**



# TECHNICAL HIGHLIGHTS



## Optimal shredding results with energy-efficient PLC control system

The PLC control system installed in the separate control cabinet regulates all processes of a horizontal shredder and can be individually configured for each application. This guarantees consistently high-quality throughput. If required, horizontal shredders can also be integrated into a production line.



## Powerful and low-maintenance drive via electric motor and V-belt

An electromechanical drive with V-belt is used to drive the V rotor installed inside the machine. It can be easily maintained and is characterized by its proven technology combined with high throughput. The absence of a gearbox or clutch also ensures low wear.

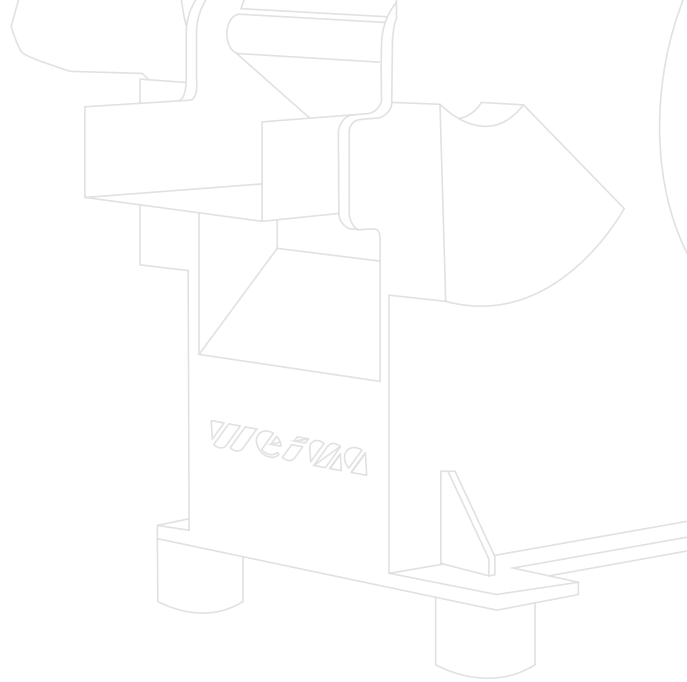

## Oversized scrap? No problem.

Extra-large shredders

Long or wide waste materials, such as panels or skeletons, often have a width that is simply too large for standard shredders. For this reason, WEIMA offers the Jumbo versions of the Tiger machines for materials with a working width of up to 1,600 mm. They not only have a wider infeed opening, but also an enlarged rotor diameter of up to 500 mm for even more throughput.



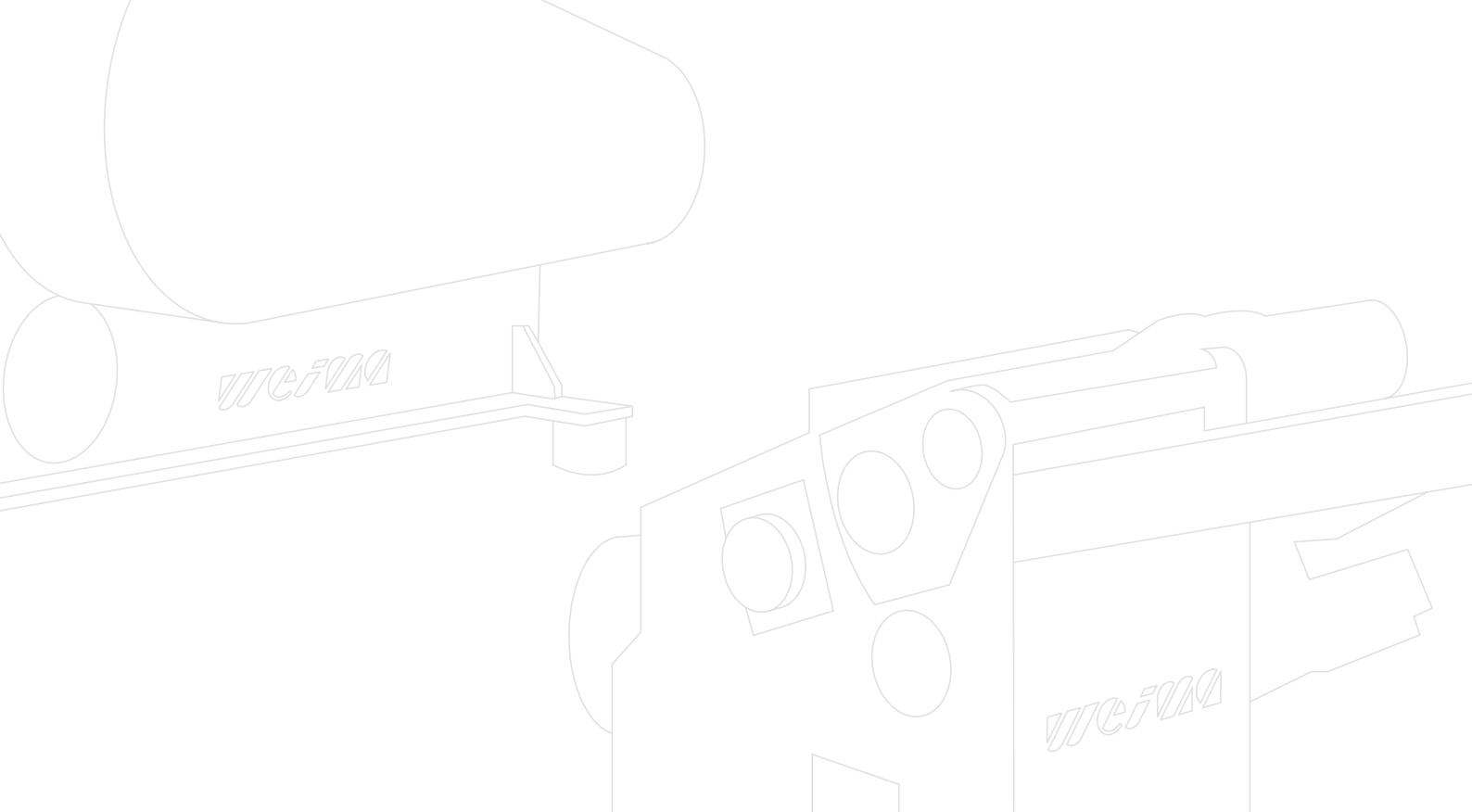

## ROBUST MACHINE DESIGN

including offset rotor bearings

WEIMA horizontal shredders are compact and robust. Rotor bearings that are offset from the machine frame are insensitive to dust, easy to maintain and durable.

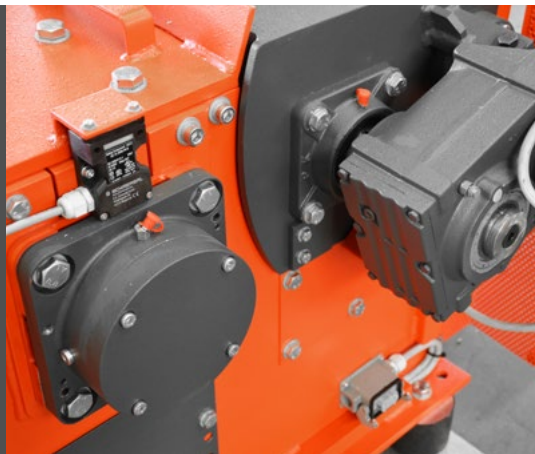

# TECHNICAL HIGHLIGHTS

Homogeneous material sizes thanks to exchangeable screen with round holes

Bolted underneath the rotor is a round hole screen, which can be replaced as required by a screen with a larger or smaller hole diameter in the range 10 - 80 mm. Material is shredded by the rotor until it fits through the hole openings, falls through, and is pneumatically discharged. This guarantees a homogeneous throughput size.

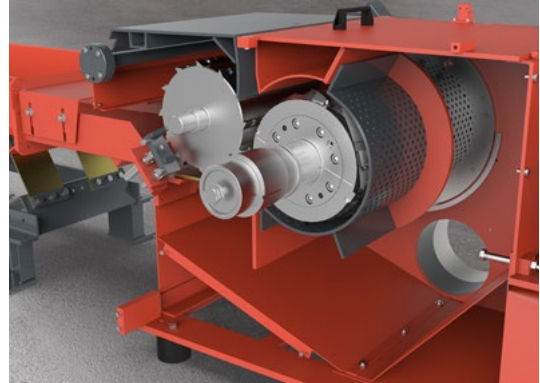

## Achieve high throughput rates

with innovative V rotor and feed roller

The cutting geometry of a shredder has a significant influence on the shredding result and the output quantity. WEIMA horizontal shredders are optimally equipped due to the aggressive, controlled material intake by means of an infeed roller and the use of two rows of rotor knives. Thus, a high throughput is achievable even with comparatively low power requirements. Wear on the cutting knives is minimal. If necessary, they can be rotated and replaced.

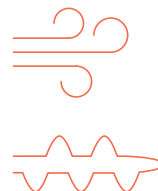

## Continuous material discharge via air system or auger

The material can be discharged from the side or rear of the machine. As a rule, the shredded material is extracted via a suction nozzle and transported to a central silo. However, a screw auger discharge can also be used. Thanks to the closed system, the risk of dust accumulation or combustion is reduced.





### Wood waste management where it's produced

In many day-to-day activities, wood scrap or offcuts of wood or plastic accumulate directly at the workstation. This is also the case, for example, with panel or table saws. Instead of collecting them separately and transporting them away, we recommend placing a horizontal shredder directly next to the machine. Waste can then be disposed of immediately and without additional effort or labor-intensive transport.

### SAFE MATERIAL FEEDING OF LONG STRIPS

via horizontal vibratory conveyor

While the Beaver machines are fed directly via a manual inclined feeder, the WLH and Tiger shredders use a vibrating infeed conveyor to feed the material. It is available in various lengths (up to 40 m) and transports long strips, profiles or pipes to the infeed roller located in front of the rotor. The roller picks up the material to be shredded and transports it horizontally to the rotor, where it is shredded between the cutting knives and counter knives. The horizontal machine design simplifies material handling of long pieces. Compared to shredders with a classic hopper, the material cannot jump out in an uncontrolled manner, which significantly increases safety.





The background image shows a modern industrial production line. In the foreground, a large orange shredder with a prominent orange safety grille is visible. The brand name 'weim' is printed on a black component of the machine. Above the shredder, a robotic arm with orange and grey segments is positioned over a conveyor system. The conveyor has several orange rollers and is carrying a long, thin white sheet of material. The background is filled with various industrial structures, including yellow safety railings and metal frames, creating a complex factory environment.

## SEAMLESS INTEGRATION INTO PRODUCTION LINES

through machine automation

If you want to increase efficiency in production, you also need to optimize waste management. Horizontal shredders are ideal for use in state-of-the-art production lines thanks to their compact design. In addition, they can be operated automatically. Modern shredders not only reduce the volume of waste and improve material flow without manual intervention, but also reduce the cost of intralogistics and labor. In addition, your shop floor becomes safer and cleaner.

## ● Technical data horizontal shredders

	Beaver 400	Beaver 1300	WLH 300	WLH 600	Tiger 400	Tiger 600	Tiger 800	Tiger 1000	Tiger 800 J	Tiger 1000 J
Feed opening length [mm]	400	1,300	300	600	400	600	800	1,000	800	1,000
Feed opening height [mm]	50	100	100	100	160	160	160	160	160	160
Rotor diameter [mm]	252	252	252	252	354	354	354	354	482	482
Power [kW]	18.5	45	18.5	37	37	45	55	75 - 90	90	90
Rotor knives [pcs]	18	70	14	32	22	32	44	56	66	82
Rotor speed [rpm]	all machines between 500 - 600 rpm									
Connection diameter [mm]	200	250	200	200	250	250	250	250	300	300
Length [mm]	2,180	2,260	1,727	1,495	1,835	1,835	1,835	1,835	2,321	2,321
Width [mm]	1,185	2,200	1,118	1,385	1,340	1,545	1,805	2,005	1,805	2,005
Height [mm]	1,085	1,100	737	770	950	950	950	950	1,513	1,513
Weight [approx. kg]	1,000	2,900	1,800	2,500	1,900	2,400	3,000	4,200	3,040	3,500

*Other variations, special equipment, and technical modifications available on request.*



**WEIMA America, Inc. | [weima.com](http://weima.com)**

3678 Centre Circle Fort Mill, SC 29715 USA

Phone: 1-803-802-7170 | Phone (toll-free): 1-888-440-7170 | Fax: 1-803-802-7098 | [info.us@weima.com](mailto:info.us@weima.com)

Subject to technical changes | 01032022