



PCM-508

PNEUMATIC CUT-OFF SAW WITH ROTARY TABLE



Authorized Dealer:

Global Sales Group, LLC
P.O. Box 1835 * Chico, CA 95927
Toll Free: 877-474-5521
Office: 530-893-2444
www.globalsalesgrouppllc.com

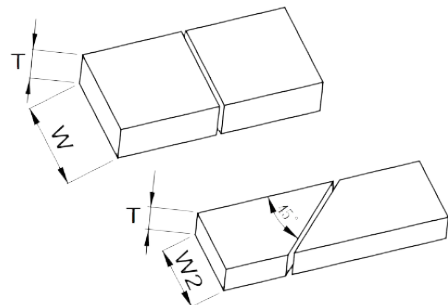

T (Thickness)		W2 (45° Bevel)	
mm	inch	mm	inch
25 mm	0.98"	200 mm	7.87"
50 mm	1.97"	190 mm	7.48"
75 mm	2.95"	175 mm	6.90"
100 mm	3.94"	100 mm	3.93"
125 mm	4.92"	125 mm	4.92"
150 mm	5.9"	85 mm	3.35"

FEATURES

- Designed for High speed, accuracy and production
- Specially designed rotary table allows angular cutting quick and easy
- The clamping mechanism is mounted with linear guide ways
- The rotary table can be swiveled to right and left with 45° (Max. 60°) angle. This allows for angular cutting.
- The table is equipped with a lock pin, allowing the table to fast lock position at 45° (60°).
- Table surface is precision ground.
- The clamping mechanism is driven by an air cylinder in combination with the use of linear guide ways, which ensure fast and smooth clamping motions.
- Infeed and outfeed fence surfaces are precision ground.
- Equipped with an anti-bump rubber stop to prevent serious bumping of clamp.
- Available in 230 / 460 / 575 V electrics

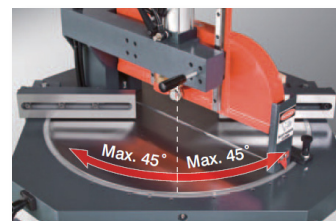

SPECIFICATIONS

Cutting capacity (Thickness x Width)	+45° (60°) ~ 0° ~ -45° (60°)
Cycle speed	30~45 cuts/min
Saw blade size (optional)	20"
Saw arbor diameter	1"
Saw blade speed	3100 rpm
Dust exhaust diameter	Ø4" x (2)
Motor	7.5 HP
Table size	36.2" x 24.8" (920 x 630 mm)
Net weight	1190 lbs (540 kg)
Gross weight	1455 lbs (660 kg)
Packing dimensions (L x W x H)	50.4" x 43.3" x 63" (1280 x 1100 x 1600 mm)

