



Authorized Dealer:
Global Sales Group, LLC
P.O. Box 1835 * Chico, CA 95927
Toll Free: 877-474-5521
Office: 530-893-2444
www.globalsalesgroupllc.com



CS-24AAT-8 24" Auto Program 8 FT Cut Off Saw
CS-24AAT-12 24" Auto Program 12 FT Cut Off Saw
CS-24AAT-16 24" Auto Program 16 FT Cut Off Saw

Optional:

- AF-MAG FEED MAGAZINE FOR PROGRAM SAW
- AF-OPT OPTIMIZE DEVICE (MAKER, CRAYON READER, TRACER FUNCTION)

Features:

- 24" auto cut off saw equipped with AF-08 auto pusher fence for added automation, efficiency and accuracy.
- Infeed table by the ordered length and 4' outfeed rollers table
- With programmable controller, it can act as AUTO STOPS or AUTO PROGRAM SIZING PUSHER for mass production jobs.
- PLC controlled automatic pusher, fence device driven by servo motor.
- Stops: Just key in the size, it will automatically move to the position, ready for the cutting size and automatically finishes the cutting cycle.
- Pusher Fence: Just key in all the sizes and each job's quantities, it will move to the material length, after loaded, it pushes to the first size, automatically completes the cutting cycle. Then it

will keep going for the quantity or the next size inputted. Continues until all the cutting has finished, and then it will automatically restart again.

- Fifty sets of job data memory, extendable: printer, PC link, and unlimited memory.
- Efficiency and accuracy for all the jobs requiring sizing such boring, drilling and cutting.
- Super traveling speed up to 200 feet per minute.
- Within 0.004" accuracy.
- Other lengths are available.
- Sealed long-life ball bearings.
- Precision ground cast iron table with heavy metal cabinet stands.
- Easy operation for furniture, lumber, door, pallet or other manufacturing.
- Saw blades come up from bottom of the table and return right after cutting for safety operation.
- Magnetic control with overload protection.
- A full saw blade guard prevents any dangers during cutting cycle.

SPECIFICATIONS	CS-18L	CS-24L	CS-24CH
Cutting Capacity	4 1/4" x 10"	8" x 11"	7-7/8" x 9 3/4"
	2 1/4" x 12 1/4"	6" x 14"	
	1 1/2" x 12 1/2"	4 x 16"	
	1/2" x 13 1/2"	2" x 17"	
Designed Cutting	45 Cycles/Min.	36 Cycle/Min.	45 Cycle/Min.
Saw Blade Diameter	18"	18" ~ 24"	18" ~ 24"
Saw Arbor	1"	1"	1"
Saw Blade Speed (RPM)	3200	2400	2400
Air Pressure	90 PSI	90 PSI	90 PSI
Dust Hood	4"	4"	4"
Motor	10 HP 3 PH 230V	10 HP 3 PH 230V	10 HP 3 PH 230V
Machine Size (W x L)	30"X 28 1/2"	51" X 43"	28" X 41"
N.W.	730 LBS	1360 LBS	1240 LBS
G.W.	800 LBS	1670 LBS	1480 LBS

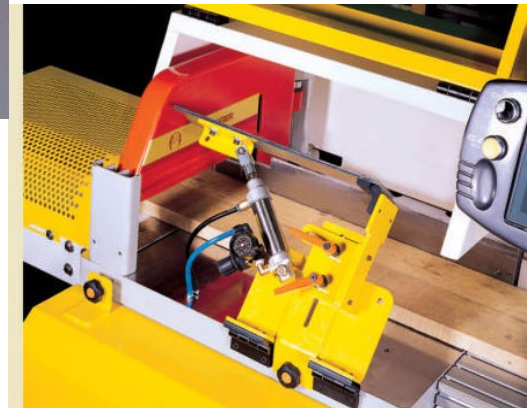
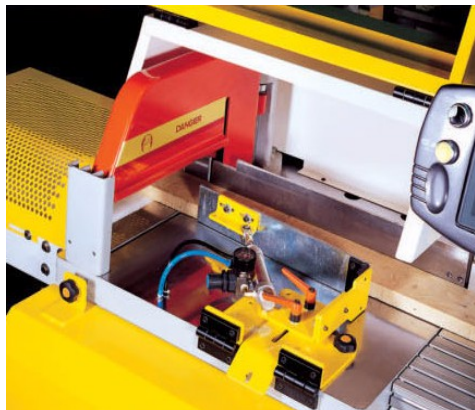

Automatic positioning system
the fast moving pusher reaches a maximum
distance of 60m/min with perfect positioning



AF-MAG FEED MAGAZINE FOR PROGRAM SAW

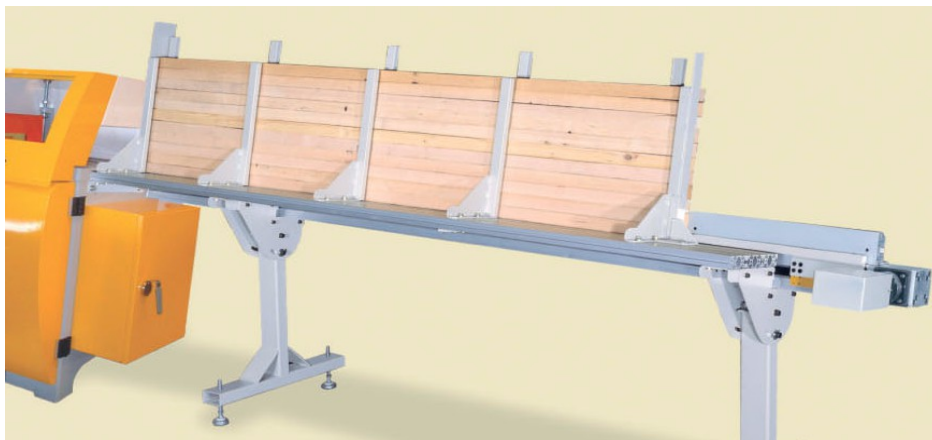
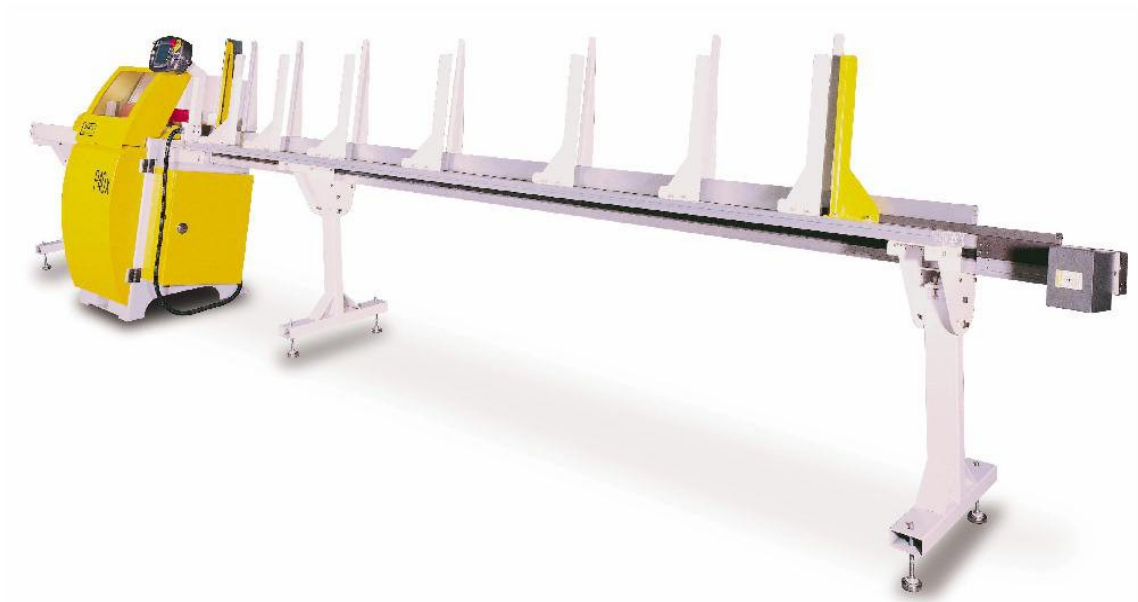



Touch screen
the touch screen's function button
allows practical understanding thus
bringing out the best of this device

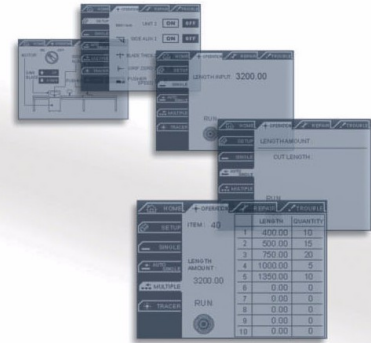

- PLC controlled automatic fence device driven by servomotor active as:
- STOP: Just key in the size, it will automatic moved to the position, ready for the job size.
- Push FENCE: Just key in all the sizes and quantities, it will move to the length then push to the first size. When the job finished, it will keepgoing for the quantity or the next size inputted continued until all the setting was finished, it will restart again.
- Standard eight sets of job data memory. Extendable: printer, PC link, and unlimited memory.
- Efficiency and Accuracy for all the jobs require sizing such boring, drilling and cutting .
- Super traveling speed up to 200 feet per minute.
- Within +/-0.10mm accuracy.
- Other lengths are available.

FUNCTION

LENGTH	SELECT
300	1
400	2
500	3
250.4	4
880	5
745	6
1125	7
955.5	8
2500	9
2500.5	10

SINGLE:
This section is acted as stopper for single size cutting. Just key in the desired size for the cutting length or choice the size from the 10 sets of memory.

AUTO SINGLE:
This section is acted as single size with multiple cutting quantities. Key in the desired cutting length, material length and the pusher will move to the size every time for the auto cutting cycle.

LENGTHAMOUNT:	2500
TRIM:	5
CUT LENGTH:	

ITEM	LENGTH	QUANTITY
1	300	3
2	400	2
3	500	1
4		
5		
6		
7		
8		
9		
10		

MULTIPLE:
This section is acted as multiple sizes and multiple quantities by automatic cutting cycle. Key in the material length, trim size, desired cutting size and quantity. The program will show the length of remain material automatically. 50 set memory with each of 10 sets of cutting length and quantity.

AF-OPT OPTIMIZE DEVICE (MAKER, CRAYON READER, TRACER FUNCTION)

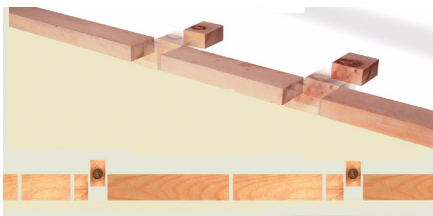

Optional equipment
Auto tracer
a fluorescent crayon is used to mark off unwanted marks on the material which is later cut off with the aid of a sensor.

This section is acted as auto defect cutting program.
To use the fluorescent crayon marked the front & back of defect parts for cutting line.

LENGTHAMOUNT:	4500
TRADE ADJUST:	90
CUT LENGTH:	150

This section It can also to set one desired cutting size between the defect parts automatically