

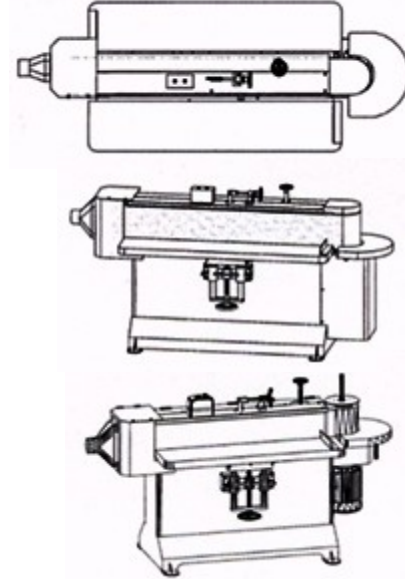

Authorized Dealer:
 Global Sales Group, LLC
 P.O. Box 1835 * Chico, CA 95927
 Toll Free: 877-474-5521
 Office: 530-893-2444
 www.globalsalesgroupllc.com



EGS-947 10" x 48" Oscillating Edge Sander

Features:

- Sandpaper automatically oscillates up & down so it will not overheat to get longer life usage and better finish result.
- 8" x 20" end table mounted at left side of the machine to use as contour sanding.
- Heavy gauge sheet metal cabinet stand and table for heavy work.
- The height of front & back table is adjustable for 5".
- Easily adjustable belt tension device.
- Two 47" W x 11-3/4" D working tables can be tilted up to 45 degrees reducing material burning and promotes longer belt life.
- The graphite pad lubricates the sanding belt and allows the belt to run cooler and smoother.
- All sealed long-life ball bearings and rubber contact motor pulley.
- Several typical profile blocks can be used for the edge profile sander.
- Powerful industrial motor for durability usage.
- Overload protect magnetic switch.

SPECIFICATIONS:	EGS-947
Max. Sanding Size	10" x 48"
Sanding Belt Sizes	10" x 141"
Belt Linear Speed	4130 FPM
Belt Drive Motor	7-1/2 HP, 3 PH
Oscillating Motor	belt drive motor
N.W.	1100 LBS
G.W.	1260 LBS

