



Authorized Dealer:
Global Sales Group, LLC
P.O. Box 1835 * Chico, CA 95927
Toll Free: 877-474-5521
Office: 530-893-2444
www.globalsalesgroupllc.com



with Optional Enclosure Cover



- CS-1C2S Through Feed 1 Shaper 2 Sander**
- CS-2C2S Through Feed 2 Shaper 2 Sander**
- CS-2C3S Through Feed 2 Shaper 3 Sander**
- CS-2C4S Through Feed 2 Shaper 4 Sander**
- CS-3S Through Feed 3 Sander Machine**
- CS-4S Through Feed 4 Sander Machine**

(We do custom design machines for your specific application)

Options:

- Floating Head Device for Arch or Pattern Cutting
- SD-AOFEED Auto Feed Magazine
- HSD 919 8.8 kw ISO 30 Quick Change Spindle
- Enclosure Cover
- Digital Control Positioning Fence for the Size

Features:

- Designed for mass shaping and sanding production for raised panel door or profile edges jobs, faster and easier.
- Heavy sheet metal frame for durability usage.
- Variable speed, through feed, 5" wide rubber pad conveyor for the best finish selections.
- Two rows heavy-duty spring pressure rolls with track belts at top to hold the material tightly to prevent sliding during the cutting and sanding process.
- Equipped with industrial motor for full power cutting and sanding capacity.
- 6" long spindle for stack-able tooling, easily adjusts and quick setup.
- X and Y axis mechanical readout for easily reset cutter or sander positions.
- Extra side roller table, extends up to 36" to support the larger width material.
- Shaper head can be moved up & down, forward & backward.
- CS-2C2S comes with first auto jump cutter head for clean cutting with no tear out at end.
- The sanding head can be equipped with brush, flap wheel or profile disc for fine finish in one pass.
- Sanding head can be tilted for different angular setup.
- Variable speed frequency controller for the sanding heads suitable for all different speed sanding wheels, disc, brush and pneumatic drum. Easy controls for machine variable speed adjustment operates from this centralized control panel.
- CS-1C1B2S with profile belt sanding head for heavy-duty sanding and extends hours of sanding belt life.

SPECIFICATIONS	CS-2C2S
MAX. WORK THICKNESS	4"
MIN. WORK WIDTH	2"
MAX. CUTTER DIA	8"
SHAPER SPINDLE LENGTH	6"
SHAPER SPINDLE DIA	1¼"
SHAPER SPINDLE SPEED	7500 RPM
SHAPER MOTOR	7½ HP X 2
SANDING SPINDLE	1"
MAX. SANDING WHEEL DIA.	8"
SANDING SPEED	0 - 3600 RPM
SANDING MOTOR	2 HP x 2
FEED SPEED (Variable)	0 ~ 90 FPM
FEED MOTOR	2 HP
NET WEIGHT	5600 LBS
GROSS WEIGHT	6100 LBS



Optional: Auto Digital Fence Position



Hogging / Jump (Floating) Head Device

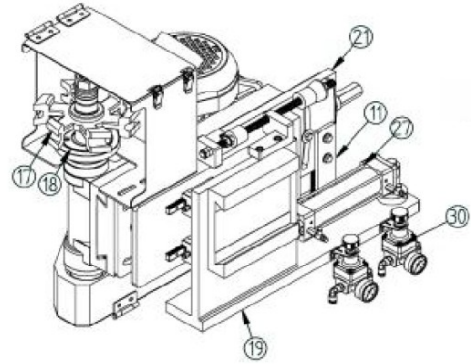

Feed Conveyor

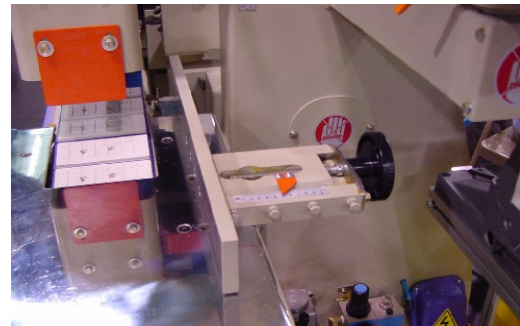

Feed Fence

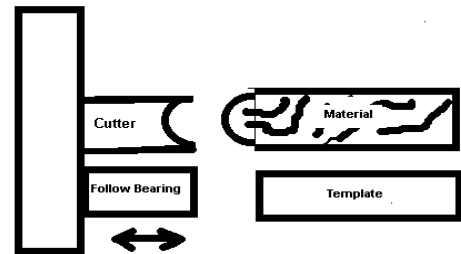
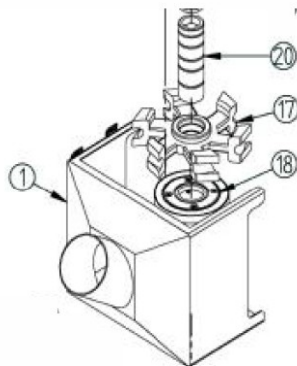
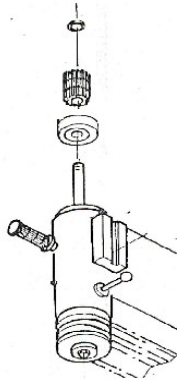

Optional Floating Head: Follow Bearing #18 for Floating to against the template for cutter in & out

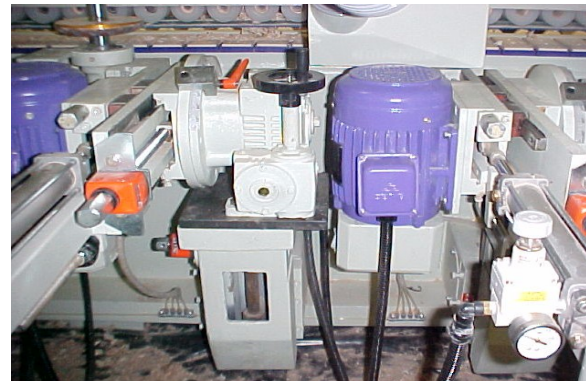

All Floating Heads Machine



E6919 NC



Optional: Auto Feed Magazine



Optional: HSD 919 Quick Change Spindle

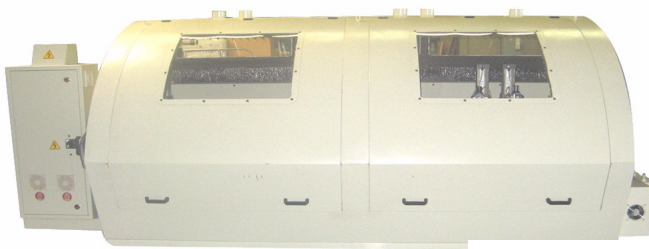

Optional : Total Enclosure Cover