



Authorized Dealer:
 Global Sales Group, LLC
 P.O. Box 1835 * Chico, CA 95927
 Toll Free: 877-474-5521
 Office: 530-893-2444
 www.globalsalesgroupllc.com



TG-923



TG-9330

TG-923 1:1 Profile Knife Grinder Machine
TG-9330 Profile Knife Grinder Machine

Features:

- Economical model for small shops.
- Work table in & out, left & right is moved on linear bearing, cross roller rail sets, for accuracy and durability.
- Easy setup template holder for copy tracer.
- Knife-edge grinding is adjusted by dovetails are grooved, grinding center is never changed, no matter what the angle is.
- Water splash guard and coolant tank, easy and efficient to operate.
- Heavy sheet metal cabinet stand and cast iron body.
- Water splash guard and coolant tank are stainless steel to protect from rusting.
- High precision and durability.

SPECIFICATIONS	TG-923	TG-9330
Grinding Capacity		
Cutter (Dia. x W)	12" x 10"	12" x 12"
Grinding Wheel Size	7.5", 60mm Dia.	8" x 2¼"
Grinding Head Travel	13"	13"
Grinding Wheel Speed	1500-4500 RPM (Var.)	1500-2900 RPM (Var.)
Grinding Wheel Motor	2 HP	2 HP
Coolant Pump Motor	1/8 HP	1/8 HP
N.W. (LBS)	1050 LBS	1100 LBS
G.W. (LBS)	1450 LBS	1500 LBS

(Training and installation, tooling & rigging are optional)
(Customer is responsible for local regulations and connecting utilities)

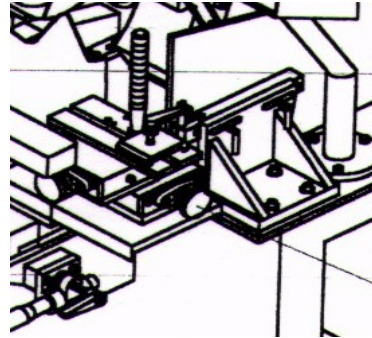
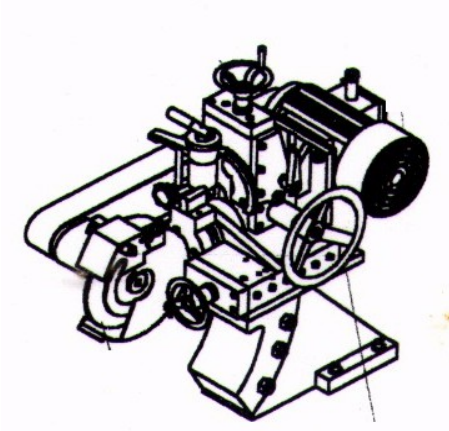

Grinding Wheel

